

NECK DETAIL

Material : HDPE

Mfg. Process	EBM	Case Pack	232 Pcs
Height (OH)	7.217" (183.3 mm)	Case Dimension	23.8" x 15.6" x 24.4"
Diameter (OD)	2.974" (75.5 mm)	Case Weight	20.3 Lb (9.2 Kg)
Overflow	12.98 ± .37 Oz (384 ± 11 ml)	Pallet Pack	20 Boxes
Gram Weight	33.4 ± 2 gr	Pallet Dimension	40" x 48" x 101"
Neck Finish	24 / 415	Pallet Weight	427 Lb (194 Kg)
Max. Print Area (Height)	5.118" (130 mm)	Pallet / 53' TL	27 Pallets
Max. Print Area (Width)	2.205" (56 mm)	Freight Class	200

12 oz. Straight Oval  
Bottle 24/415

Part # : 12G25

Dwg. # PLA-S-700

Rev. 0



Ph. (909) 930-6100  
info@plastirey.com  
www.plastirey.com

No portion of this drawing may be reproduced without express written permission of Plastirey Containers. Specifications subject to change without notice.

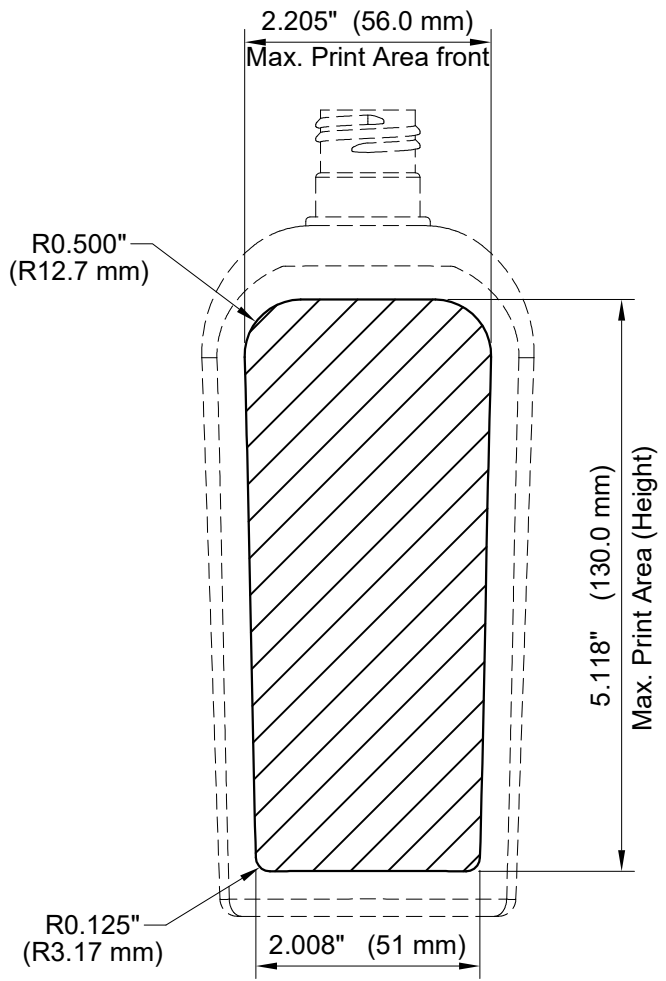

Front View

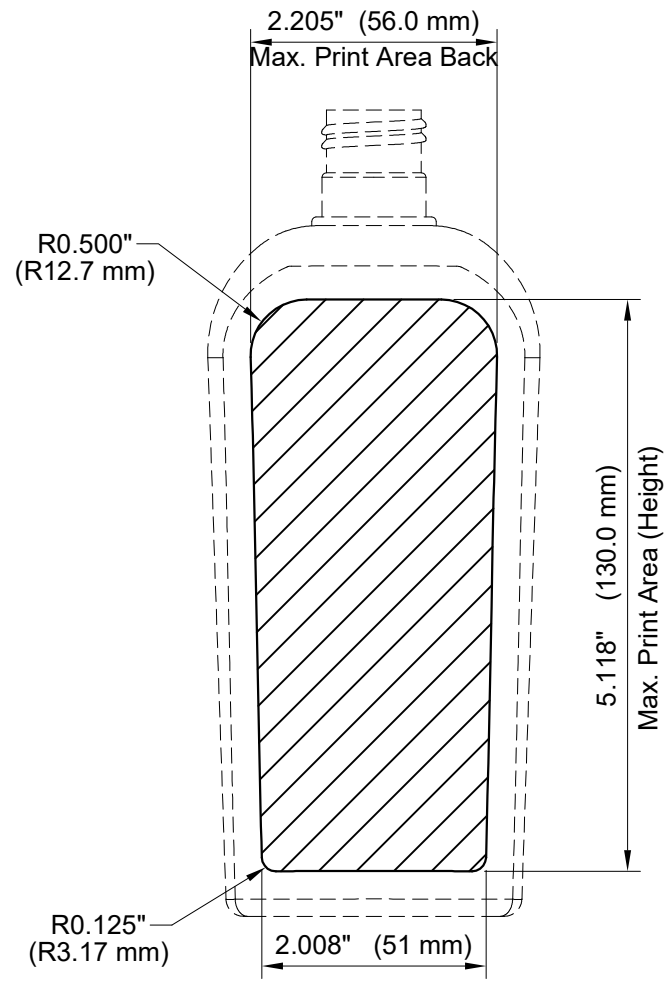

Back View

 Art Work Area

<p>12 oz. Straight Oval Bottle 24/415</p>		
<p>Part # : 12G25</p>		
<p>Dwg. # <b>PLA-D-700</b></p>	<p>Rev. <b>0</b></p>	
<p>Ph. (909) 930-6100 info@plastirey.com www.plastirey.com</p>		