

BOTTLE	TUBE LENGTH
04F43	4.567" ± .079" (116 ± 2 mm)
08F43	7.323" ± .079" (186 ± 2 mm)

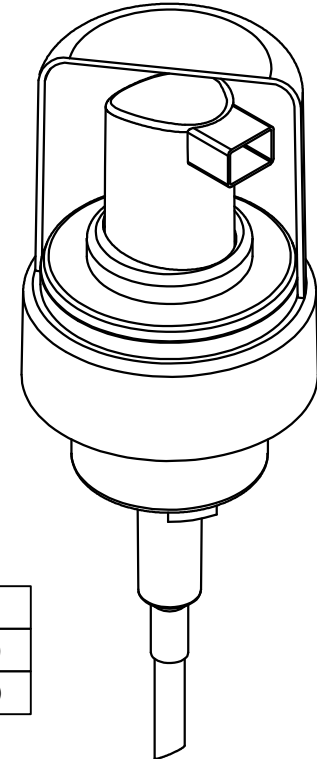

Material : -

Mfg. Process	IM	Case Pack	480 Pcs
Height (OH)	-	Case Dimension	17.7" x 15.4" x 23.5"
Diameter (OD)	-	Case Weight	34.2 Lb (15.5 Kg)
Overflow	--	Pallet Pack	18 Boxes
Gram Weight	30.7 gr	Pallet Dimension	53" x 31" x 75"
Neck Finish	43 mm	Pallet Weight	637 Lb (289 Kg)
Max. Print Area (Height)	--	Pallet / 53' TL	30 Pallets
Max. Print Area (Width)	--	Freight Class	110

**43 mm Foamer Pump  
with PP Overcap**

**Part # : U6310**

Dwg. # **PLA-S-571**

Rev. **C**



Ph. (909) 930-6100  
info@plastirey.com  
www.plastirey.com

No portion of this drawing may be reproduced without express written permission of Plastirey Containers. Specifications subject to change without notice.