

NECK DETAIL

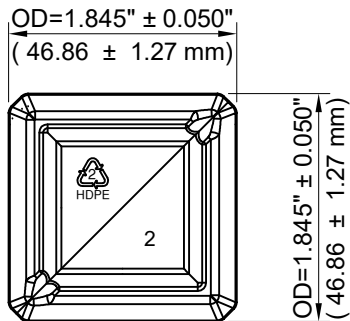

Material : HDPE

Mfg. Process	EBM	-	Case Pack	344 Pcs.
Height (OH)	6.230"	(158.24 mm)	Case Dimension	23.8" x 15.6" x 24.4"
Diameter (OD)	1.845"	(46.86 mm)	Case Weight	21.4 Lb (9.7 Kg)
Overflow	9.13 ± .24 Oz	(270 ± 7 ml)	Pallet Pack	20 Boxes
Gram Weight	24 ± 2 gr		Pallet Dimension	40" x 48" x 101"
Neck Finish	24 / 410		Pallet Weight	454 Lb (206 Kg)
Max. Print Area (Height)	4.296"	(109.12 mm)	Pallet / 53' TL	27 Pallets
Max. Print Area (Width)	1.254"	(31.85 mm)	Freight Class	200

8.5 Oz Square
24/410 Bottle

Part # : U9907

Dwg. # PLA-S-716

Rev. A



Ph. (909) 930-6100
info@plastirey.com
www.plastirey.com

No portion of this drawing may be reproduced without express written permission of Plastirey Containers. Specifications subject to change without notice.

Left View

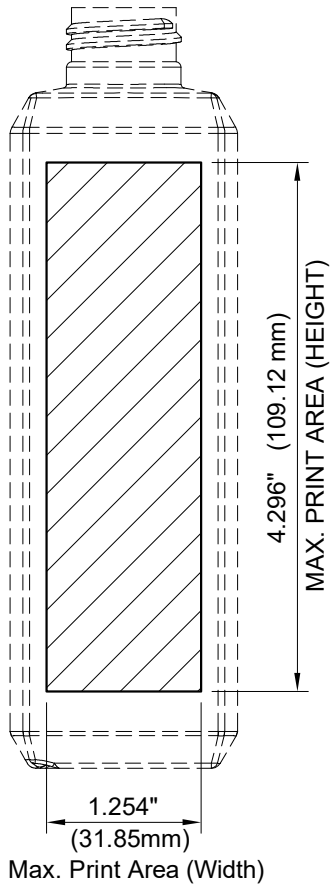

Front View

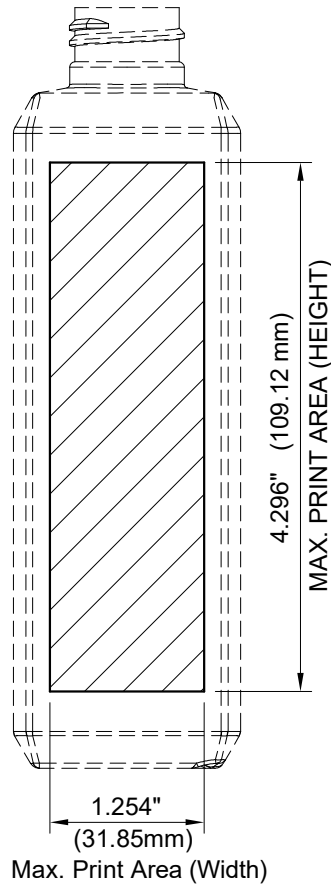

Right View

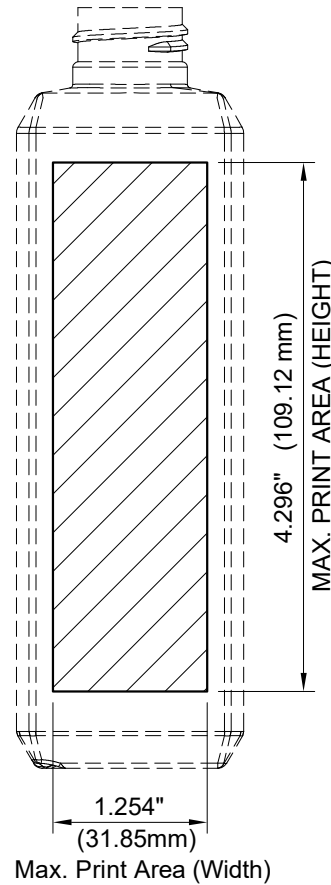

Back View

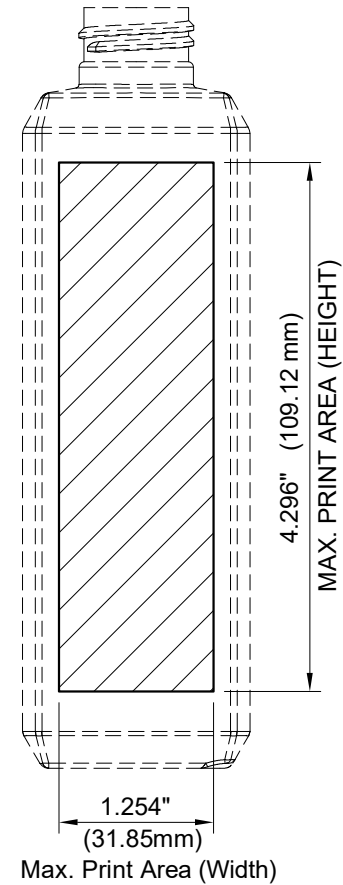

 Art Work Area

8.5 Oz Square
24/410 Bottle



Part # : U9907

Ph. (909) 930-6100
info@plastirey.com
www.plastirey.com

Dwg. #
PLA-D-716

Rev.
A